

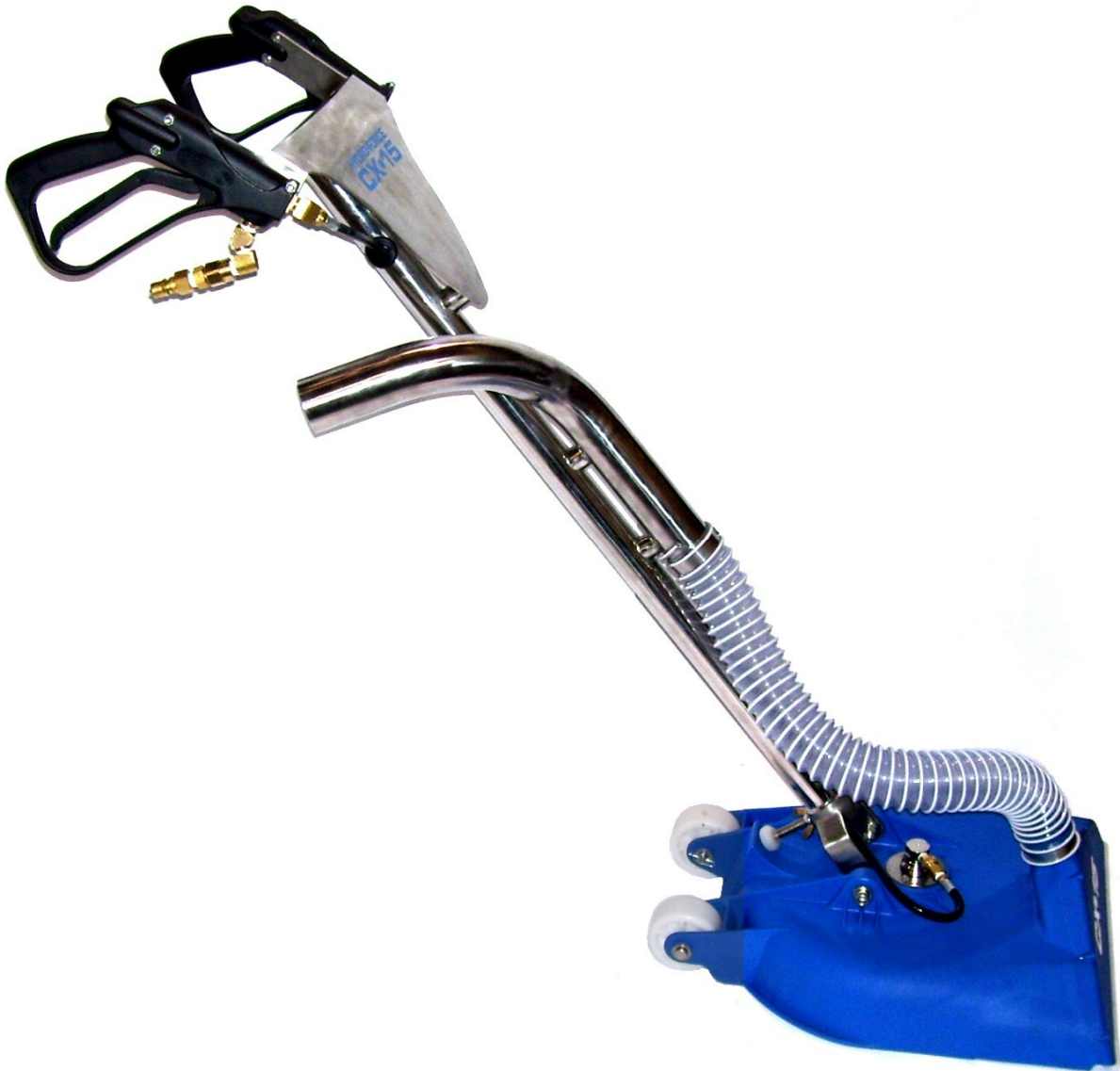

HYDRO-FORCE™

CX-15 ROTARY CARPET EXTRACTOR OPERATOR'S MANUAL



Aramco
4282 South 590 West
Salt Lake City, UT 84123
801-268-2673
801-268-3856 FAX

LMANAW115
Revised: 03/12/2019

CX-15 Operator's Manual
TABLE OF CONTENTS

<u><i>TOPIC</i></u>	<u><i>PAGE #</i></u>
• Introduction	3
• Technical Specifications	4
 <u>SECTION 1: Operational Safety</u>	
• Safety	5
 <u>SECTION 2: Operation Procedures</u>	
• Spray Bar & Jet Selection	6
• Pressure & Flow Requirements	7
• Handle Adjustment	7
• Hose Connection	7
• Cleaning Procedures	8
• Shutdown Procedure	9
 <u>SECTION 3: Maintenance/ Technical</u>	
• Troubleshooting	10
• Maintenance	11
• Drawings & Parts Lists	15
• Warranty	24

Introduction

Congratulations on your purchase of the Hydro-Force CX-15 Rotary Carpet Extractor. The CX-15 is designed to give professional cleaning performance with either truck mounted or portable extractors. Years of experience, engineering, and planning have gone into the design and manufacturing of the CX-15. We take a great deal of pride in the CX-15; our goal is no less than your complete satisfaction.

This manual will provide users with the knowledge required to operate the Hydro-Force CX-15 safely, to understand how to properly operate and maintain the machine, and to ensure that the equipment operates at its maximum performance level.

All users must read and understand this manual completely before operating the machine. Place this manual in a secure location for future reference.

Always maintain this manual in legible condition adjacent to the Hydro-Force CX-15, or place in a secure location for future reference.

Any questions pertaining to the operating or servicing of this unit should be directed to your nearest Hydro-Force distributor.

This manual is written specifically for the Hydro-Force CX-15 rotary extractor units manufactured by:

AramSCO
4282 South 590 West
Salt Lake City, UT 84123
801-268-2673
801-268-3856 FAX

Information in this manual is subject to change without notice and does not represent a commitment on the part of Hydro-Force or its parent or affiliated companies.

Technical Specifications

CX-15 Rotary Carpet Extractor

Height: 46.3" with handle

Length: 19"

Width: 17.3"

Weight: 15.8 lbs.

Standard Equipment

CX-15 Carpet Cleaning Tool

Spray Bars: Residential 40° Drive Angle* / 0° Kick Angle**/ 11002 SS Jets

Commercial 30° Drive Angle* / 7.5° Kick Angle**/ 1502 SS Jets

*See Operation Procedure Section on page 6 for the definition of Drive Angle.

**See Operation Procedure Section on page 6 for the definition of Kick Angle.

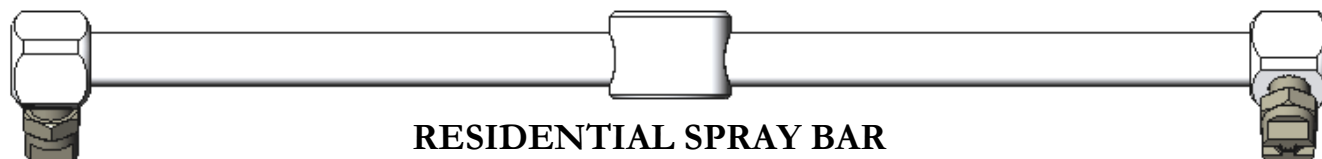

Additional / Optional Equipment

Hydro-Force Pro Solution Hose 1/4" x 25' Blue: (w/o Quick Connects)	AH170
Hydro-Force Pro Solution Hose 1/4" x 50' Blue: (w/o Quick Connects)	AH176
Hydro-Force Pro Solution Hose 1/4" x 100' Blue: (w/o Quick Connects)	AH172
Hydro-Force Pro Solution Hose 1/4" x 150' Blue: (w/o Quick Connects)	AH174
1/4" Male Quick Connect:	AH102B
1/4" Female Quick Connect:	AH101B
Ball Valve 1/4" M-F	AH54
Vacuum Hose 2" x 50' with Cuffs – Blue	AH32H
Vacuum Hose 2" x 50' with Cuffs – Orange	AH30H
Vacuum Hose 2" x 50' with Cuffs – Grey	AH34
Vacuum Hose 1.5" x 50' with Cuffs – Blue	AH38CH
Vacuum Hose 1.5" x 50' with Cuffs – Orange	AH31H
Vacuum Hose 1.5" x 50' with Cuffs – Grey	AH36BH
Vacuum Hose 1.5" x 25' with Cuffs – Blue	AH38BH
Vacuum Hose 1.5" x 25' with Cuffs – Orange	AH29H
Vacuum Hose 1.5" x 25' with Cuffs – Grey	AH36BH
Cuff 2" for 1.5" Hose	AH46

Safety

WARNING! This tool must be protected from freezing conditions which may damage the valves, swivels, hoses and other components.

- **Freezing of water in this tool will cause damage.** The CX-15 must be protected from freezing temperature. Store, transport, and use this equipment only in temperatures well above freezing. (32°F or 0°C). If you suspect the CX-15 has been frozen, do not try to operate until you are sure it has thawed completely.
- If the tool cannot be stored or transported in a warm environment, it can be guarded from freezing by running an anti-freeze solution through the tool or using compressed air to blow the water out of the tool. If anti-freeze is used, the anti-freeze solution must be completely flushed from the tool before it is returned to service.

WARNING! Rotating Spray Bar can cause Injury

- Keep Hands & Feet away from CX-15 head while operating tool.
- Keep all body parts, hair, and loose clothing away from openings and moving parts. Always wear appropriate clothing and safety equipment when operating unit.
- Disconnect Solution Hose from CX-15 before attempting to change Spray Bars.

WARNING! High Pressure water at high temperatures can cause Injury

- Do not clean with solutions that are at temperatures above 250°F.
- HP hoses may rupture if worn or damaged. Do not use tool if solution hose covering is cut, bulging, or otherwise damaged. Examine HP solution hoses daily and replace or repair hoses as needed.

*****Use common sense to protect yourself and others while using this equipment.*****

- Keep pets and children away from the machine when in use.

Operation Procedures

SET UP AND OPERATION

1. Spray Bar Selection:

The different spray bars are designed for different carpet types. Two different Spray Bars are included with the CX-15:

Residential Spray Bar:	40° Drive Angle / 0° Kick Angle / 11002 SS Jets
Commercial Spray Bar:	30° Drive Angle / 7.5° Kick Angle / 1502 SS Jets

Spray Bars are stamped with an **R** for Residential or **C** for Commercial for easy identification.

The **Drive Angle** is the angle of the spray jet in relation to the floor. The Drive Angle is a major factor along with the spray jet and water pressure in determining the spray impact and rotation speed of the CX-15 Spray Bar. A Drive angle of 0° would point straight down at the floor. While a Spray Bar with a 0° Drive angle would have high spray impact, the Spray Bar would not rotate. A Spray Bar with a 90° Drive Angle would rotate very fast, but would have no spray impact. Extensive testing was run to find the optimum Drive Angle, jet and pressure combination for maximum performance.

The **Kick Angle** is the angle of the spray jet out from the center axis of the Spray Bar rotation. The Kick Angle is a major factor along with the spray jet and water pressure in determining the cleaning area covered by the CX-15. A Kick Angle of 0° points straight down. A jet with a wide spray pattern can be used with a 0° Kick Angle. A more narrow spray pattern jet must be used with a Spray Bar with a greater Kick Angle to attain coverage of the maximum cleaning area.

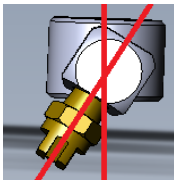

DRIVE ANGLE

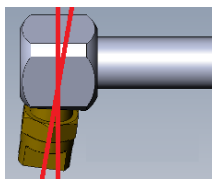

7.5° KICK ANGLE

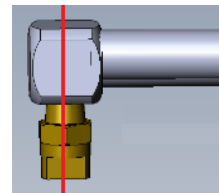

0° KICK ANGLE

We recommend using the different Spray Bars only on the following carpet types:

RESIDENTIAL SPRAY BAR: Carpet with the potential to “bloom”. Cut Pile Carpets such as Saxony, Plush Piles, Sculptured or Textured Carpets & Frieze Carpets.

COMMERCIAL SPRAY BAR: Durable Closed Loop type carpets.

Install the correct Spray Bar for the type of carpet you will be cleaning.

If you are unsure of which Spray Bar to use, select the Residential Spray Bar.

The Residential Spray Bar is less likely to cause fiber damage.

Refer to the Spray Bar Installation Instructions on Page 12.

CAUTION:

- Using the Commercial Spray Bar on Cut Pile carpets may cause damage to carpet fibers.
- Using different jet sizes than those noted above may cause damage to the carpet fibers.

2. Water Pressure & Flow Requirements:

The solution pump providing the water pressure to operate the CX-15 requires the following:
Adjust your system solution pressure for the best cleaning performance on the type of carpet you will be cleaning.

Required Pump Flow & Pressure: 1.80gpm @ 800psi

Recommended pressure for Residential Spray Bar on Cut Loop Carpet – 400psi

Recommended pressure for Commercial Spray Bar of Closed Loop Carpet – 500-800psi

- ☞ Operation with a lower pressure setting will slow the Spray Bar rotation and may require more time to clean the carpet properly.
- ☞ Operation with a higher pressure setting may cause the Spray Bar to spin too fast, exceeding the recommended operation speed of the swivel. The increased agitation at higher pressures may damage carpet fibers.

CAUTION:

- Exceeding the recommended pressure may cause damage to carpet fibers.
- Exceeding the recommended pressure may over spin the jet bar and damage the swivel.

3. Connection of Solution Hose:

Connect the solution hose from your extractor to the 1/4" Male Quick connect on the Spray Gun Assembly on the right side handle of the CX-15.

CONNECT SOLUTION HOSE HERE

4. Connection of Vacuum Hoses:

Connect the vacuum hose from your extractor to the 2" Vacuum pipe on the handle of the CX-15. A 2" cuff is recommended and will fit over the outside of the pipe. A 1-1/2" cuff can be used. It will fit inside the pipe, but may not seal as well.

CONNECT VACUUM HOSE HERE

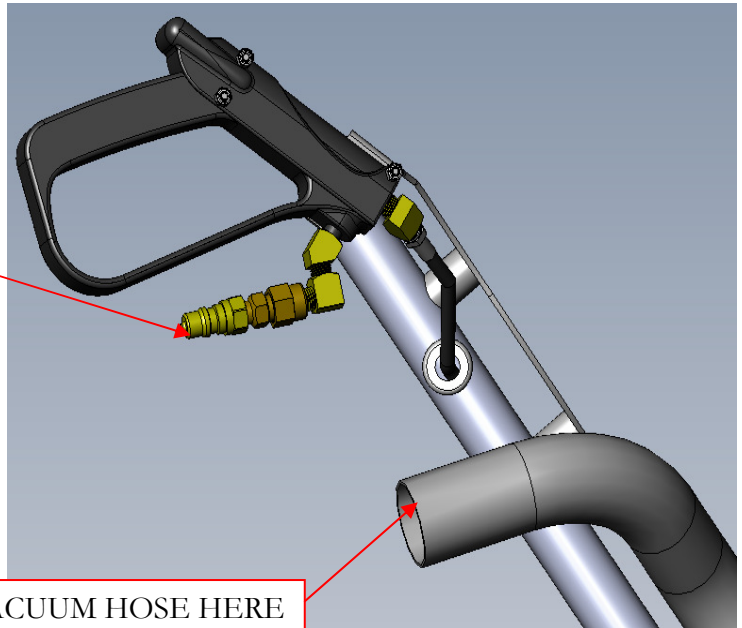

5. Adjusting The Handle Stop:

The Handle Stop can be adjusted to set the CX-15 handle height for comfortable operation.

Loosen the Handle Stop Wing Nut.

Turn the Handle Stop Bolt IN or OUT as needed to change the position of the handle when the Handle Stop Bolt contacts the Handle Stop on the CX-15 Main Body. The CX-15 Handle should be adjusted such that your arms are in a comfortable position while keeping the CX-15 head level and the Glide Plate on the carpet while pulling the CX-15 back during each cleaning pass. Once set, tighten the Handle Stop Wing Nut to lock the Handle Stop Bolt in place.

HANDLE STOP WING NUT

MAIN BODY HANDLE STOP

HANDLE STOP BOLT

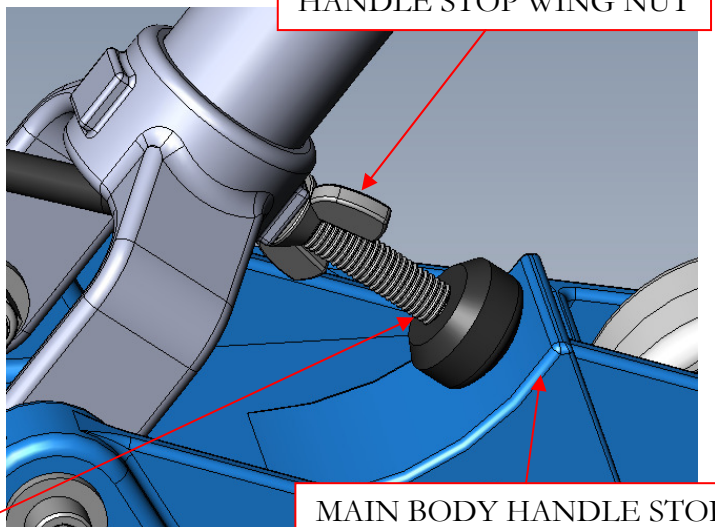

6. Cleaning Procedure:

Determine Spray Bar to Use

It is up to the operator to ascertain which spray bar (residential or commercial) will be used, and the solution pressure to use. See #1 above for information about this decision. If unsure of the proper spray bar to use, clean the carpet in an inconspicuous area and inspect to make sure there is no fiber damage; default to using the Residential Spray Bar if you're still unsure.

Adjust Handle Stop

The handle stop's purpose is to allow forward movement with the CX-15. On some carpet types, because of pile type, or lay of the nap, the CX-15 is unable to be pushed forward. The design of the glide permits extreme water removal when moving backwards, but can sometimes "suck down" when moving forward. To break this vacuum seal, the operator pushes down on the handle, the handle stop bolt contacts the top of the CX-15 deck and the front of the CX-15 is raised off the carpet – breaking the vacuum seal.

Vacuum Carpet

Vacuum the carpet or use a counter rotating brush machine to remove debris and dry soil from the carpet.

Prespray Carpet

Prespray the carpet with your selected cleaning solution. Allow it to dwell for 5 or 10 minutes but do not allow it to dry before applying the extraction process using the CX-15.

Clean and Extract with CX-15

Pull the handle back to tilt the CX-15 back onto its wheels and roll the CX-15 into position to make the first cleaning pass.

Simultaneously squeeze the trigger on the spray gun and pull the CX-15 back. This achieves the cleaning and extraction stroke. Note: Holding the solution on and not moving the tool at the same time will result in a "clean circle" being created on the carpet. These can be very difficult to remove. If done to the extreme it may also damage the carpet fibers. When depressing the trigger always maintain movement to prevent clean circles.

As you near the end of the cleaning pass, release the trigger on the Spray gun to stop the solution spray. Continue to pull the CX-15 back until you have vacuumed over the entire sprayed section of carpet. If needed, you can now make a drying pass with no solution flow by either pushing the CX-15 forward, or turn around and make a cleaning pass back in the other direction over the same path or a new path adjacent to the first path, overlapping slightly.

Repeat with as many cleaning and drying passes as needed to clean the entire area.

NOTE: The CX-15 uses high-pressure solution and a spray bar with jets at each end that are angled so as to cause the spray bar to spin at a high speed. The direct impact of the solution spray, combined with cleaning chemistry that may be applied, acts to agitate the fibers, dislodge, rinse and extract the spent solution in one step. By drawing the CX-15 rotary extractor over the carpet in a continuous backward motion, the carpet fibers are impacted from different angles creating an amazing cleaning result. At the discretion of the operator, the CX-15 may be used in a frontward and backward scrub motion while maintaining the solution spray in the on position. This will generally only be useful on a low pile commercial carpet and then caution must be exercised to avoid over agitation of the carpet fiber and over wetting.

Note: Check the vacuum glide on a regular basis to make sure no debris is stuck in the slot. A clogged glide could result in uneven removal of the solution.

7. Shutdown Procedure:

- a. Turn the extractor solution pump off.
- b. Squeeze the trigger of the CX-15 Spray Gun to release the pressure.
- c. Pull the CX-15 over the area where the jets sprayed when the pressure was released to recover the water.
- d. Disconnect the solution hose and vacuum hose.
- e. Use the vacuum hose to remove any fibers, dirt and debris under the CX-15.
- f. Turn the extractor vacuums off.
- g. Rinse off the glide and underside of CX-15 to remove hair, fibers and dirt.
- h. Collect the CX-15 and hoses and return them to your van or other storage area.

Troubleshooting

Section

3

Troubleshooting – Hydro-Force CX-15

Problem	Cause	Solution
No water Spraying	Solution Hose not connected	Connect Solution hose to CX-15
	Ball Valve Closed on Solution Hose	Open Ball Valve
	Spray Gun Valve Stuck Shut	Repair or replace Spray Gun Valve
	Defective Quick Connect	Repair or replace quick connect
	Filter Screen Plugged	Clean or replace filter screen
	Spray Jets plugged	Clean out or replace jets
	Extractor Pump turned Off	Turn Pump On
	Extractor Pump not pumping	Check pump operation & flow – Repair or Replace
	Solution Hoses Disconnected	Check & re-connect all connections between sections of hose
	Solution Hose Plugged	Check & clean out or replace hoses
Spray Bar not Spinning	Pressure too low	Check Pump rating & operation – Repair or replace
	Flow Rate too low	Check Pump rating & operation – Repair or replace
	Filter Screen Plugged	Clean or replace filter screen
	No water spraying	See previous section on No Water Spraying
	Jets Plugged	Clean Out or Replace Jets
	Bad Swivel	Replace Swivel
Not picking up water	Vacuum Hose not connected	Connect Vacuum hose to CX-15
	Vacuum Glide Plugged	Clean out Vacuum Glide Slot
	Lid off extractor waste tank	Replace lid
	Extractor Drain Valve Open	Close Valve
	Tank Full – Vac Shutoff Engaged	Drain Tank
	Filter clogged	Clean Filter
	Vacuum Hose plugged or leaking	Clean Out, Repair or replace vacuum hoses
	Vacuums not running	Check Extractor & repair as needed
Glide Catching on carpet	Glide Worn	Replace Glide
	Screws on glide loose	Tighten or replace screws
	Debris embedded in Glide	Clean off or replace Glide
Handle lock Does not Hold handle up	Handle Lock Nut Loose	Readjust Handle Lock & tighten Wing Nut
	Handle Lock out of adjustment	Readjust Handle Lock & tighten Wing Nut
	Handle Lock Stop Damaged	Replace Main Body of CX-15
Contact your distributor for additional troubleshooting assistance, to order parts or for advice and assistance in performing necessary repairs.		

Maintenance

Proper maintenance is required to keep the CX-15 operating properly, prevent downtime and to extend the life of your equipment.

WARNING: Disconnect solution hose before performing any service or maintenance inside machine base, spray gun valve or solution filter.

OPERATION	INTERVAL	Page #
Cleaning the Solution Filter	Once a month or more often as needed	12
Changing the Spray Bar Assembly	Before each job as needed	13
Inspect Glide Plate	Before each job	13
Replace Glide Plate	As Needed	13
Freeze Protection	Before storage as needed.	14

Cleaning the Solution Filter:

A dirty or clogged Solution Filter on the CX-15 will reduce the flow rate of water to the spray jets. This will reduce the cleaning effectiveness of the CX-15 and prevent the Spray Bar from spinning at the proper speed.

The Solution Filter Screen NA0803 is in the Filter Body NA0802, between the 1/4" Male Quick Connect AH102B and the Filter Adapter NA0804.

To remove the Solution Filter use a 13/16" wrench to hold the Filter Adapter and an 11/16" wrench to turn the Filter Body.

Usually the filter screen will fall out or is easily pulled out of the Filter Body. If extremely dirty, you may need to pry the filter screen out with a small flat head screwdriver.

Washout the filter screen or use an air gun to blow the debris off of the screen. If the screen is damaged it should be replaced.

Place the Filter Screen back into the Filter Body. Apply Teflon Tape to the male threads of the Filter Body and screw it back into the Filter Adapter and use your 13/16" & 11/16" wrenches to tighten the fittings.

Test the CX-15 operation before returning to service.

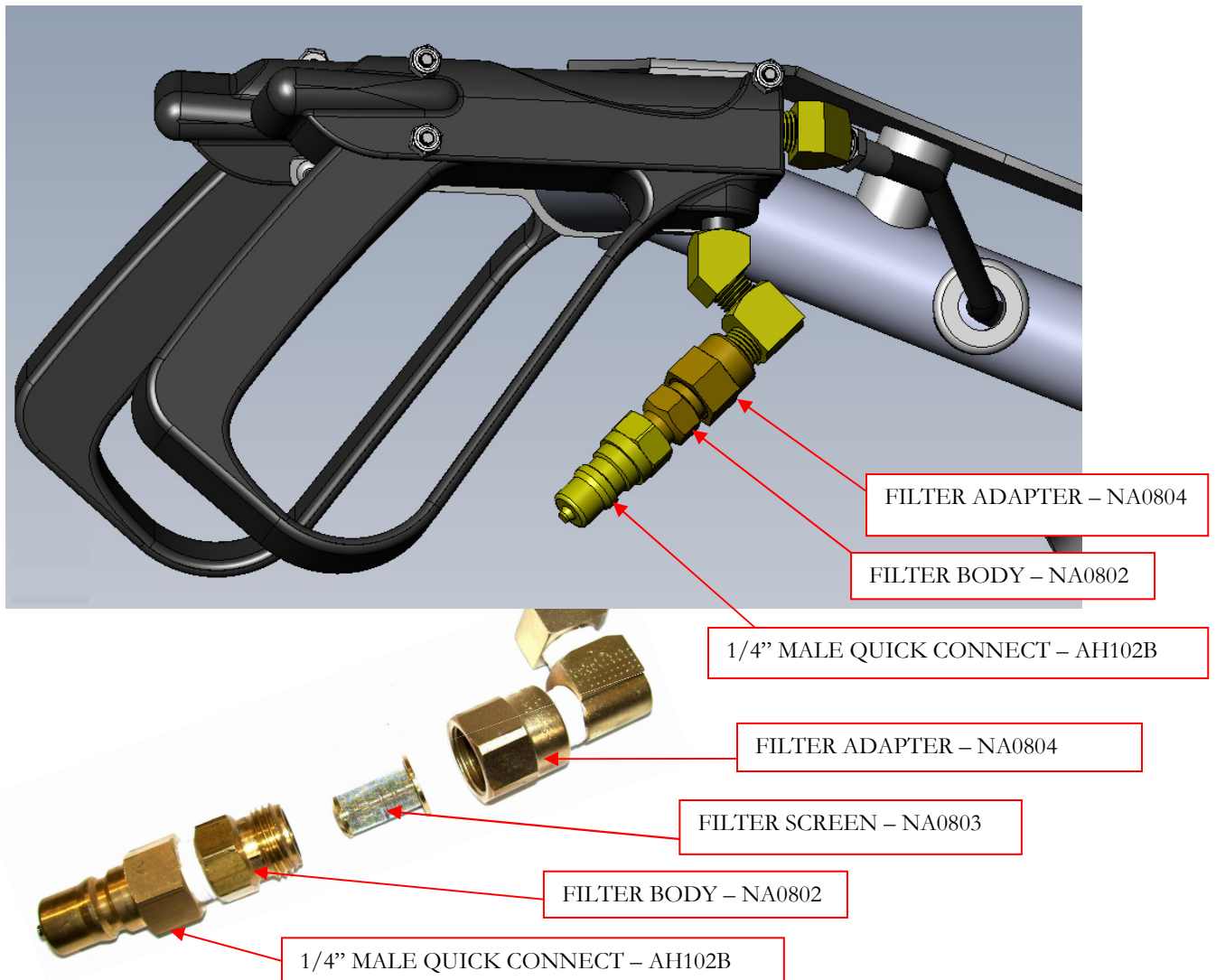

Changing the Spray Bar Assembly:

It is important that the correct Spray Bar be used for different carpet types.

(See Spray Bar selection instructions on Page 6)

To clean different types of carpeting you will have to change your Spray Bar Assembly.

Always disconnect the Solution Hose from the CX-15 before attempting to service or change the Spray Bar.

Use a 3/4" Wrench to hold the hex on the Swivel to prevent the Swivel from turning. Use the heel of your hand to push on one end of the Spray Bar to rotate the Spray Bar counter-clockwise. Once it is loosened, you can then spin it to remove it from the Swivel. The Spray Bar usually can be loosened with just your hand, but in some cases, especially if you have not changed the Spray Bar in a long time you may need to tap the Spray Bar with a rubber mallet to loosen it.

Once you have selected the correct Spray Bar Assembly for the type of carpet you are cleaning, hold the Swivel with the 3/4" wrench and spin the new Spray Bar clockwise onto the Swivel. Use the heel of your hand to push on one end of the Spray Bar to tighten it. Just make it snug, do not over tighten.

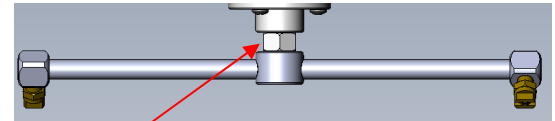

Hold Swivel Hex with 3/4" Wrench

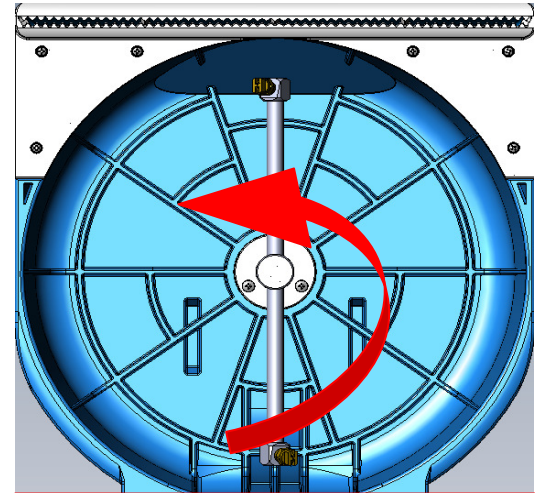

Turn Spray Bar Counter-Clockwise to remove Spray Bar from Swivel

Inspecting & Changing the Glide Plate:

With normal use, the Glide Plate will last for years, but as the carpet contact point for the CX-15, over time, the Glide Plate may wear out or get damaged. Before each job, inspect the Glide Plate. Look for and remove any debris or grit which may be imbedded in the Glide Plate surface. Check for rough edges or nicks which could snag the carpet. A file, emery board or a fine grit sanding block can be used to smooth the Glide Plate surface. A worn glide may not seal as well or a damaged glide could snag the carpet.

To replace the Glide Plate, first remove the three screws from the front bottom of the CX-15 head, then flip the tool over and remove the six screws on the bottom of the Glide Plate.

(Do not mix up the screws. The front screws & bottom screws are different.)

Place the new Glide Plate NM6004 onto the bottom of the CX-15 body assembly and replace the nine screws. Test the CX-15 operation before returning to service.

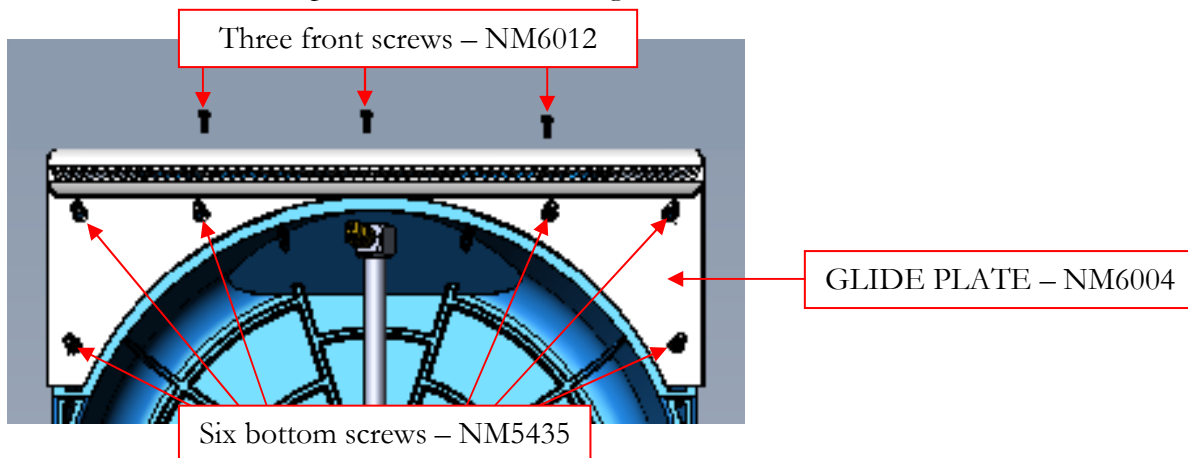

Freeze Protection Procedure:

Your Hydro-Force CX-15 must be protected from freezing. Freezing can cause serious damage to any component containing water. If the CX-15 is transported or stored in freezing temperatures, the following procedures should be performed:

Anti-Freeze Solution Method:

It is recommended that a non-toxic anti-freeze such as propylene glycol be used to freeze guard this tool. Follow all local and federal laws regarding the disposal of any anti-freeze solution.

Pour an anti-freeze solution into the solution tank or water box of your extractor.
(Refer to your extractor operator's manual section regarding freeze guard instructions for the extractor to determine the best method to run anti-freeze through your extractor.)

The solution must be of sufficient dilution to prevent freezing at the expected low temperatures in your area. Refer to the anti-freeze container label or check with the manufacturer to determine the dilution rate required.

Connect the solution hose to the extractor and the 1/4" Male Quick Connect on CX-15 tool Spray Gun. Turn on the extractor pump. (The pressure does not have to be high enough to spin the Spray Bar.) Hold the CX-15 over a bucket to collect the water & anti-freeze sprayed from the tool. Squeeze the trigger on the CX-15 Spray gun to spray water from the tool and continue to spray until you see anti-freeze being sprayed from the CX-15 jets. Turn off the extractor pump. Disconnect the solution hose from the CX-15.

Compressed Air Method:

Connect a compressed air hose to the 1/4" Male Quick connect on the CX-15 Spray gun. Hold the CX-15 over a bucket to collect the water sprayed from the tool. Squeeze the trigger on the CX-15 Spray gun to spray water from the tool and continue to spray until you no longer see water being sprayed from the CX-15 jets. Disconnect the compressed air hose from the CX-15.

RETURNING THE CX-15 TO SERVICE AFTER STORAGE OR FREEZE PROTECTION:

To return the CX-15 to service, the anti-freeze must be flushed from the machine. Flush the anti-freeze out of the machine by repeating the procedures above using fresh water in place of anti-freeze.

PARTS

Drawings Used to Identify Parts for your CX-15

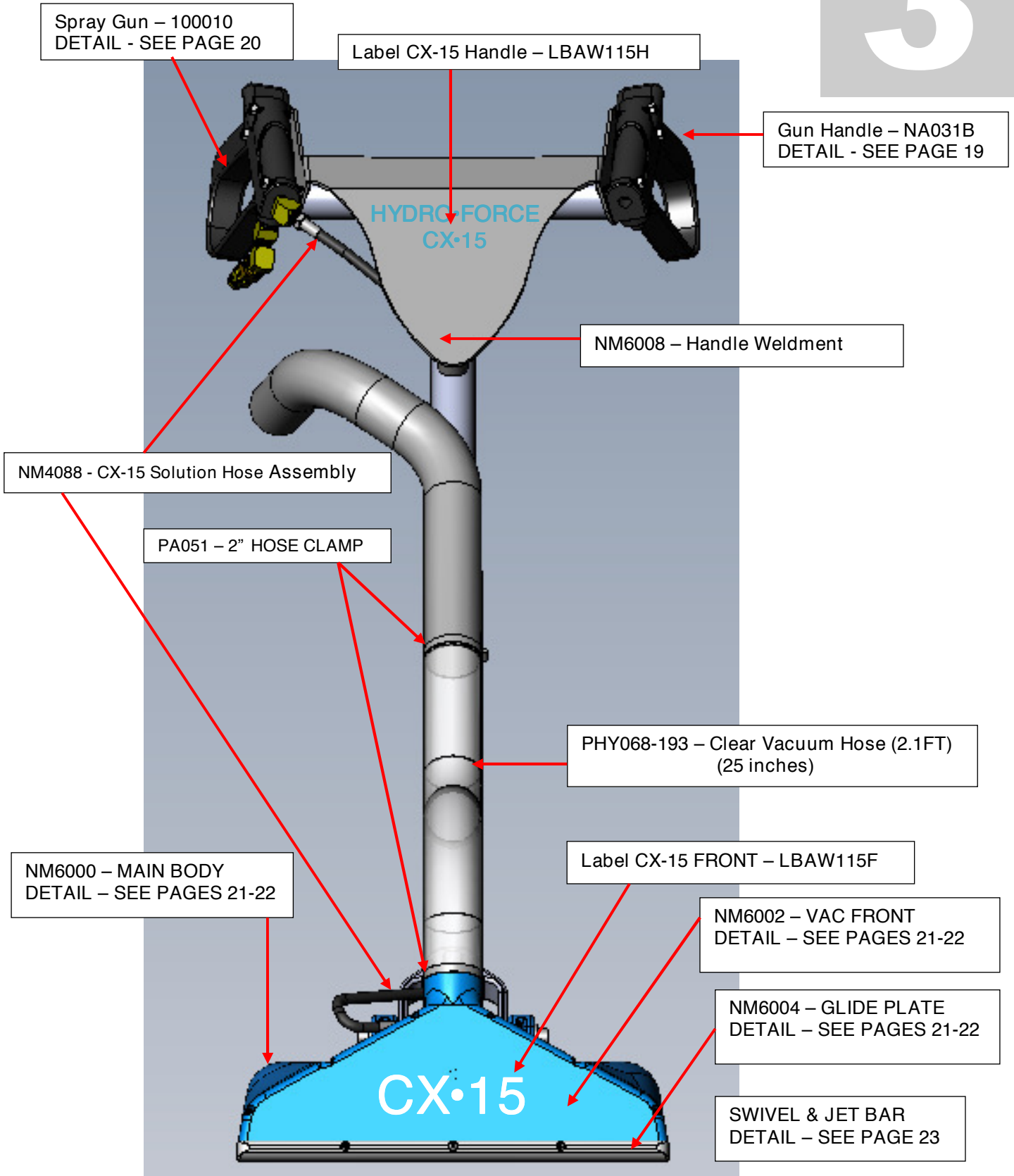

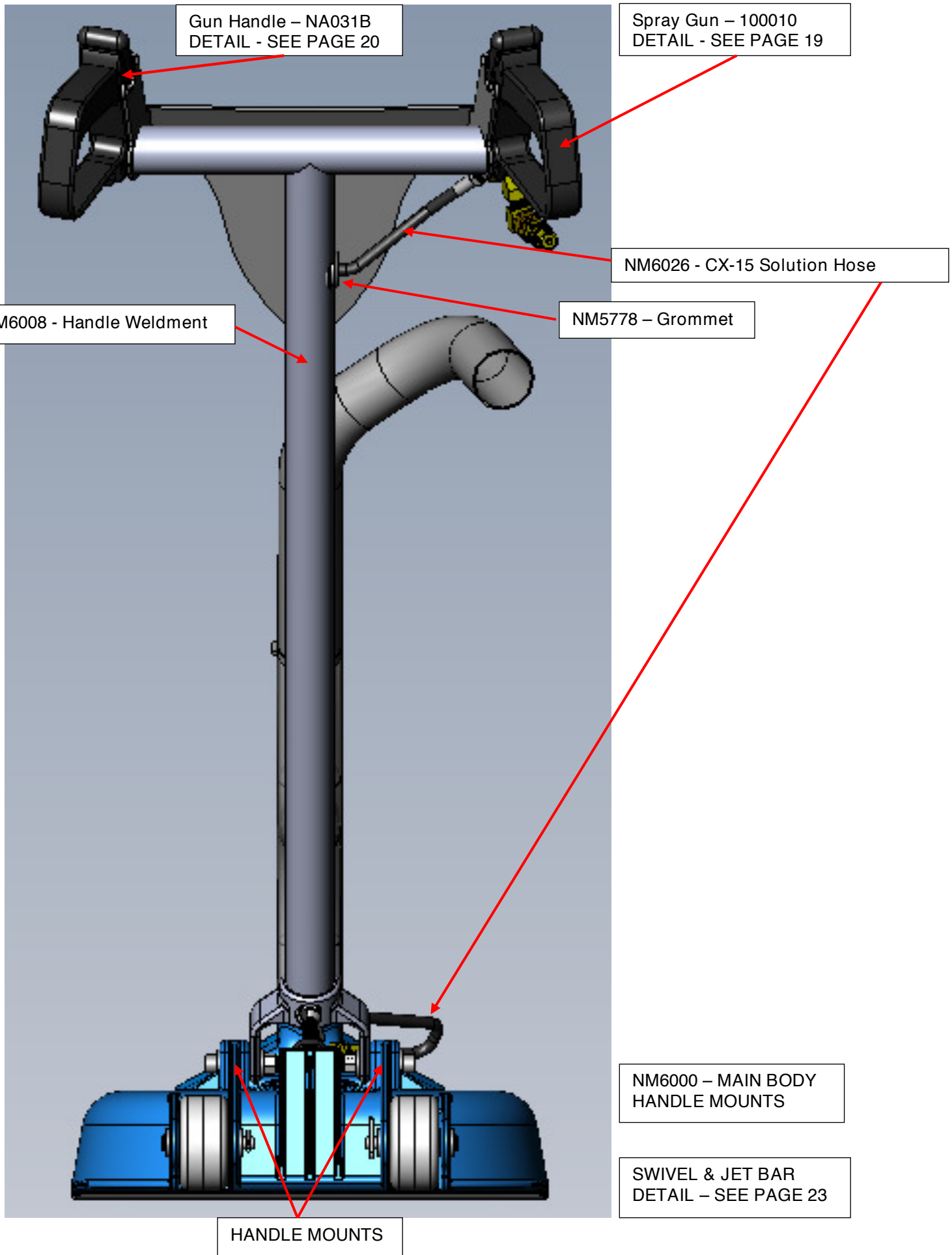

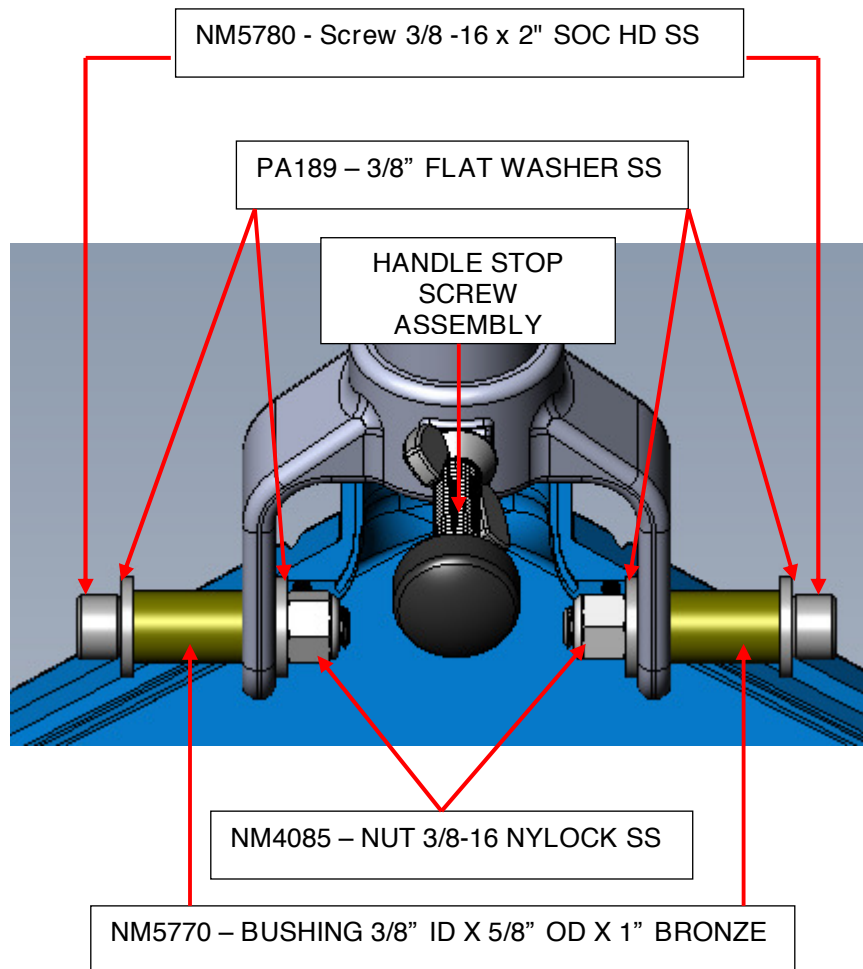
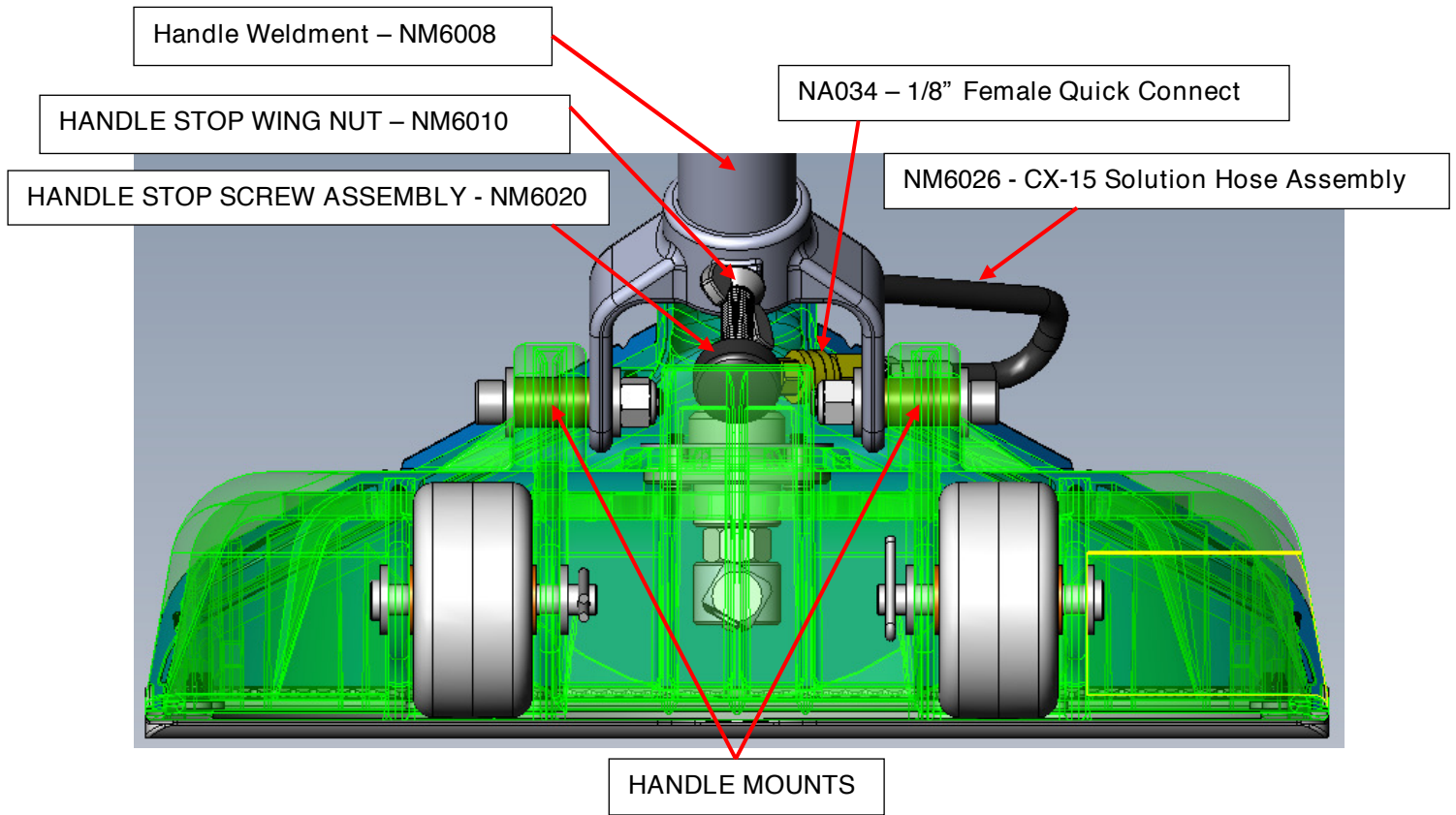

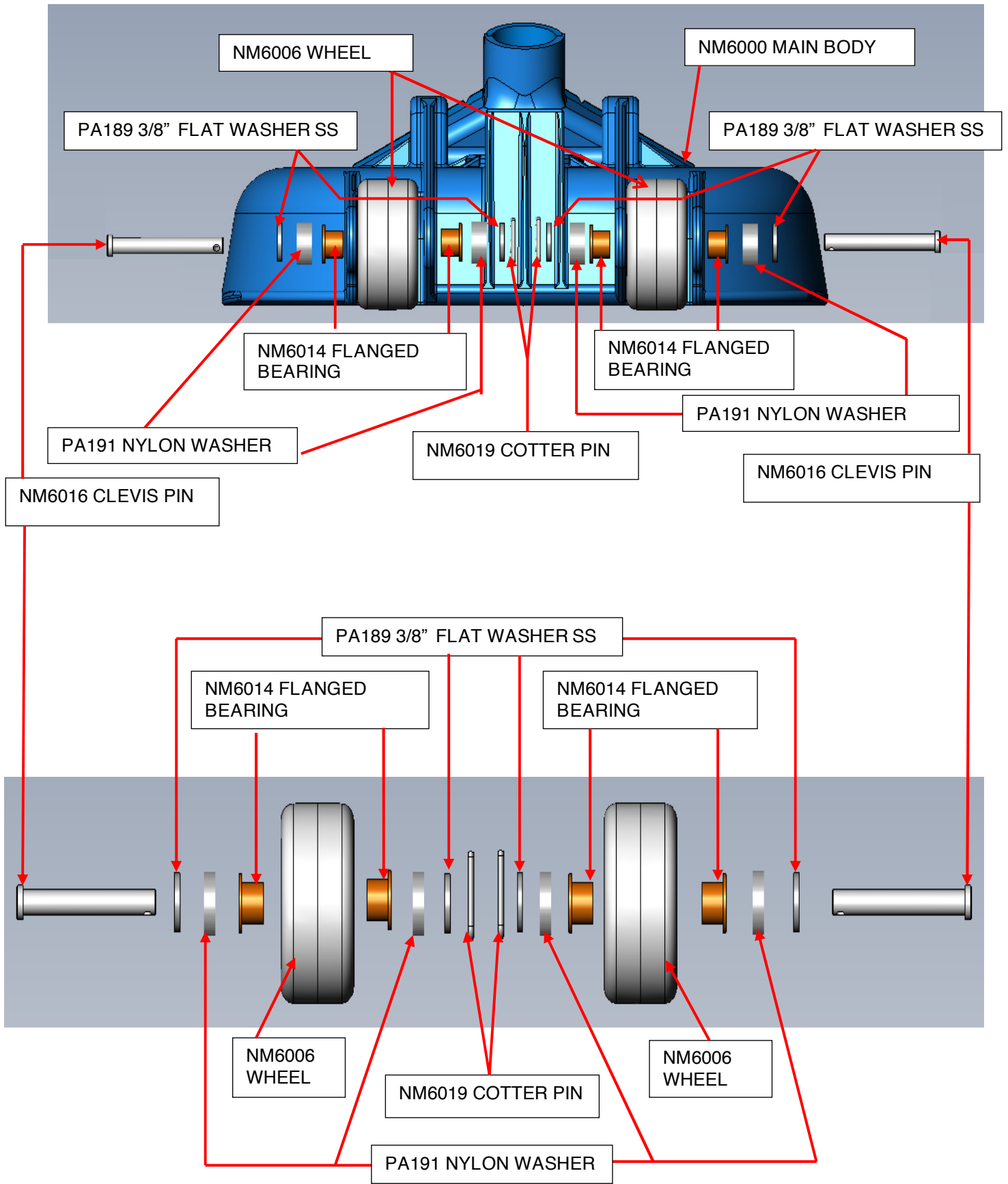



BR272



BR282



NA0804



NA0803



NA0802



AH102B

45° Elbow - BR272

90° Elbow - BR282

Filter Adapter - NA0804

Filter Screen - NA0803
(Not Shown inside Filter Body)

Filter Body - NA0802

1/4" Male QC - AH102B

Three 3/16" Holes
drilled for Mounting
Screws

Spray Gun - 100010

NM4080 - Screw 10-32 x 1-5/8" SS BHSOC
NM4028 - Nut 10-32 Nylock

NM6026 - CX-15 Solution Hose Assembly

NM5778 - Grommet

NM6008 - CX-15 Handle Weldment

Gun Handle - No Valve - NA031B
(Modified for three mounting screws)

Spray Gun - 100010
(Modified for three mounting screws)



Replacement Valve - NA033
For Spray Gun 100010



Valve Repair Kit - NA033A
For Spray Gun 100010

Three 3/16" Holes drilled for Mounting Screws

Gun Handle – No Valve & No screws – NA031B
(Modified for three mounting screws)

NM5629 - Screw 4mm x 20mm Self Tap PPH Black



NM4080 – Screw 10-32 x 1-5/8" SS BHSOC
NM4028 – Nut 10-32 Nylock

Spray Gun – 100010
(Modified for three mounting screws)

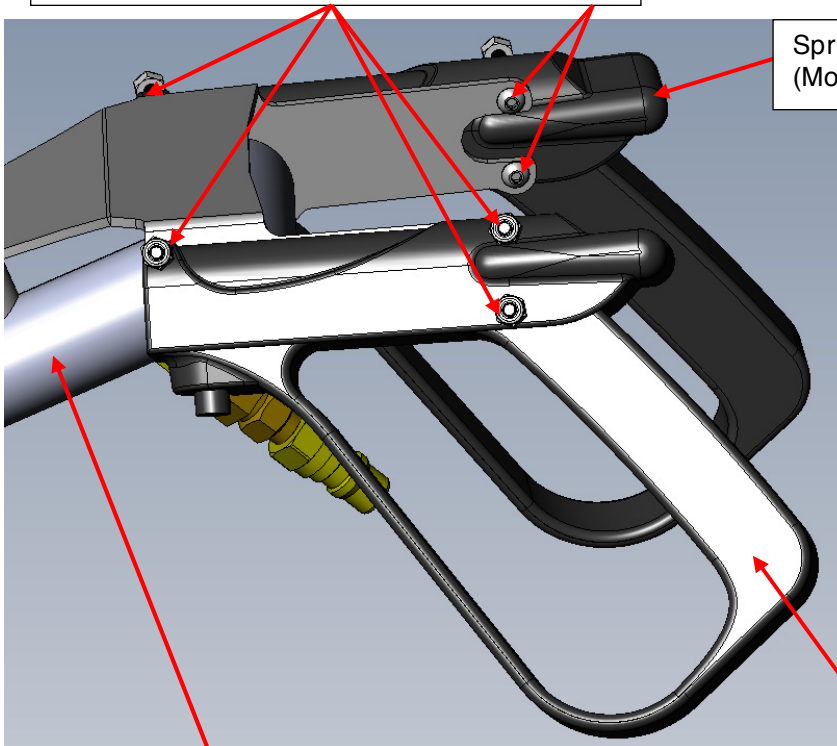

NM6008 – CX-15 Handle Weldment

Gun Handle – No Valve & No screws – NA031B
(Modified for three mounting screws)

NM6012 6-18 x 7/16" Thread Forming SS Screw (Qty 9)

Handle Mounts

NM6000 Main Body

Wheel Mounts

NM6004 Glide Plate

NM5435 6-32 x 7/16" PPH SS Screw (Qty 8)

NM6002 Vac Front

Handle Mounts

Wheel Mounts

Swivel Mount

NM6002 Vac Front

NM6004 Glide Plate

NM5435 6-32 x 7/16" PPH SS Screw (Qty 6)

NM6000 Main Body

Wheel Mounts

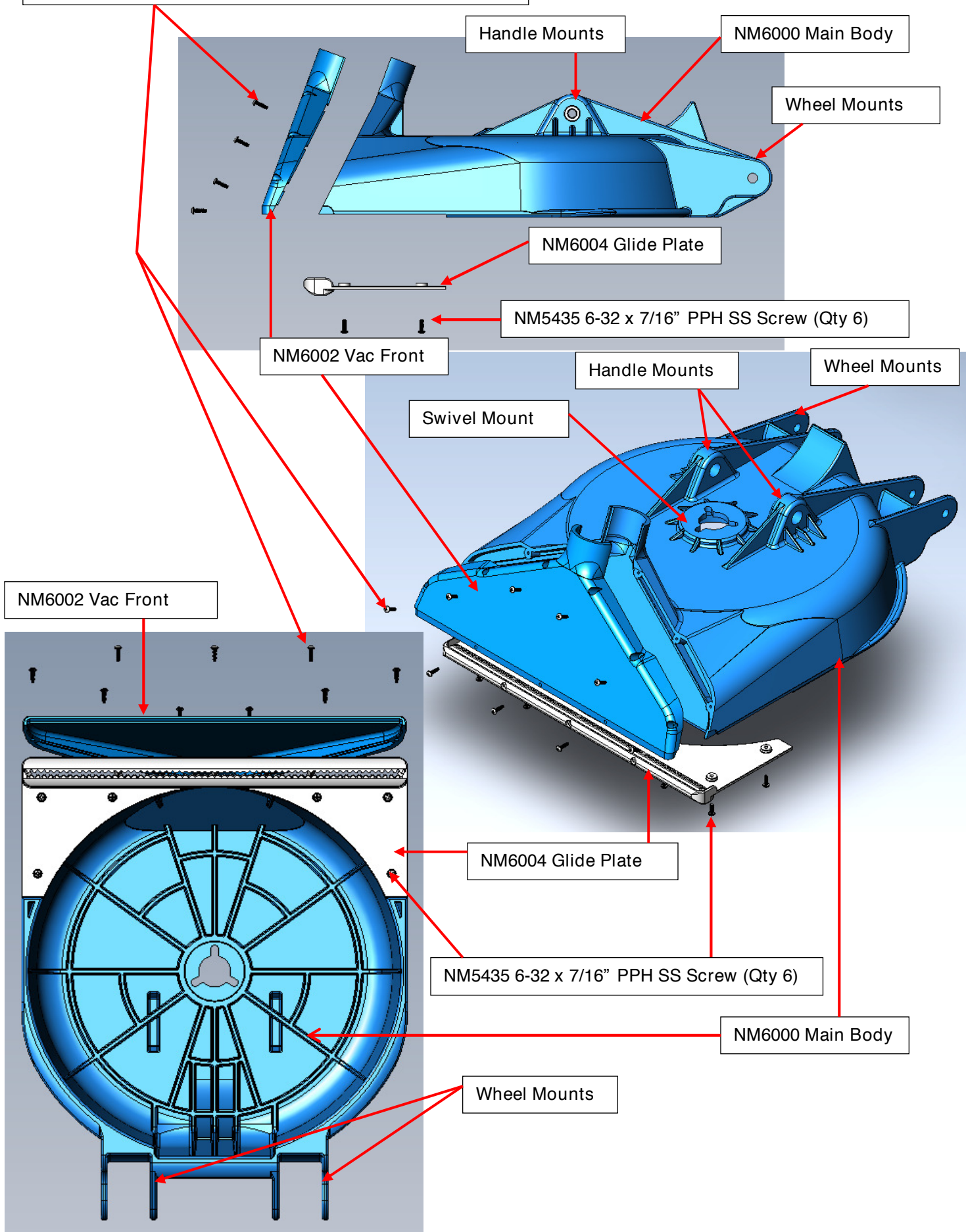

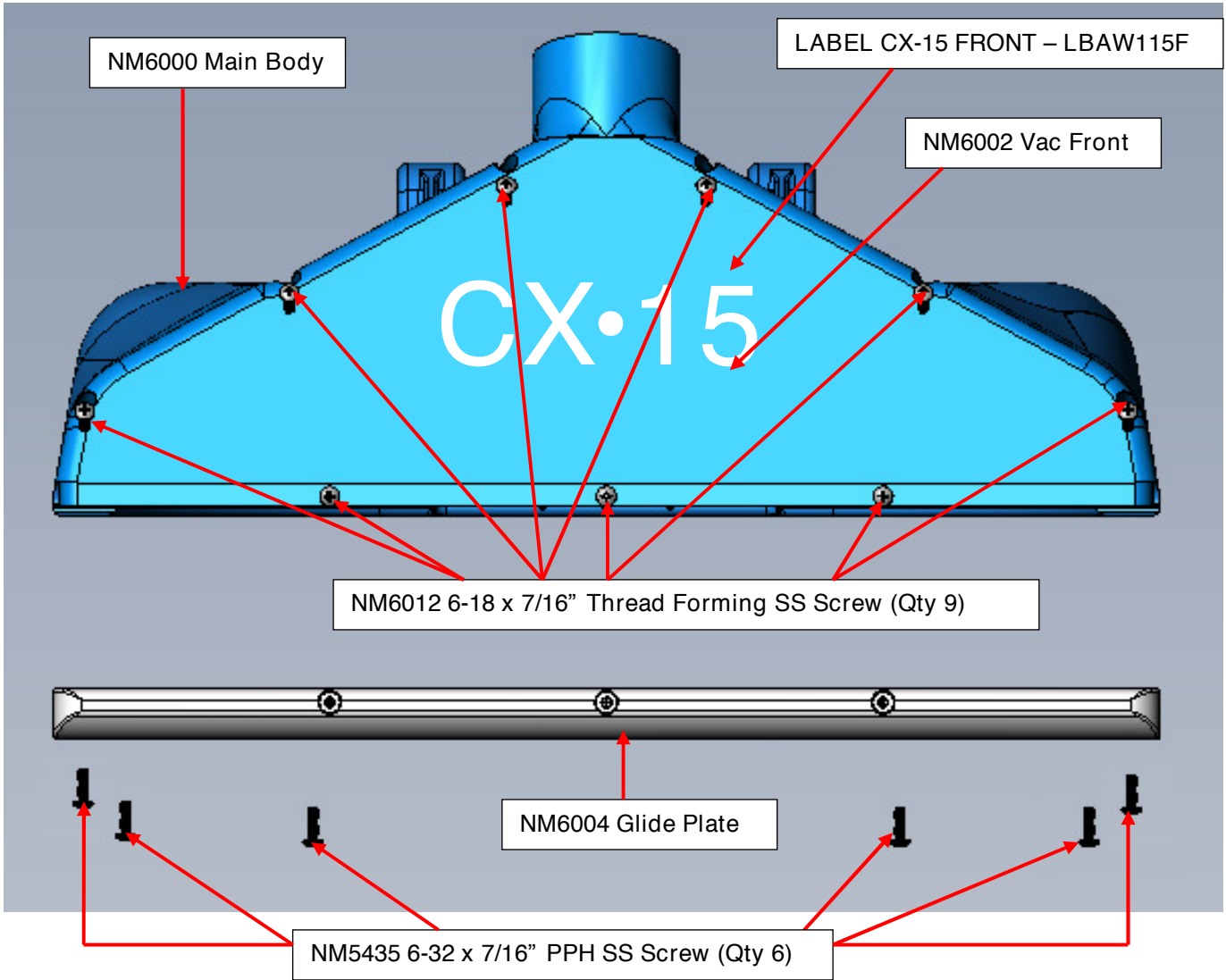

NM5645 - ROTARY WASHER WITH PEM NUTS

NM6000 MAIN BODY

NM6002 VAC FRONT

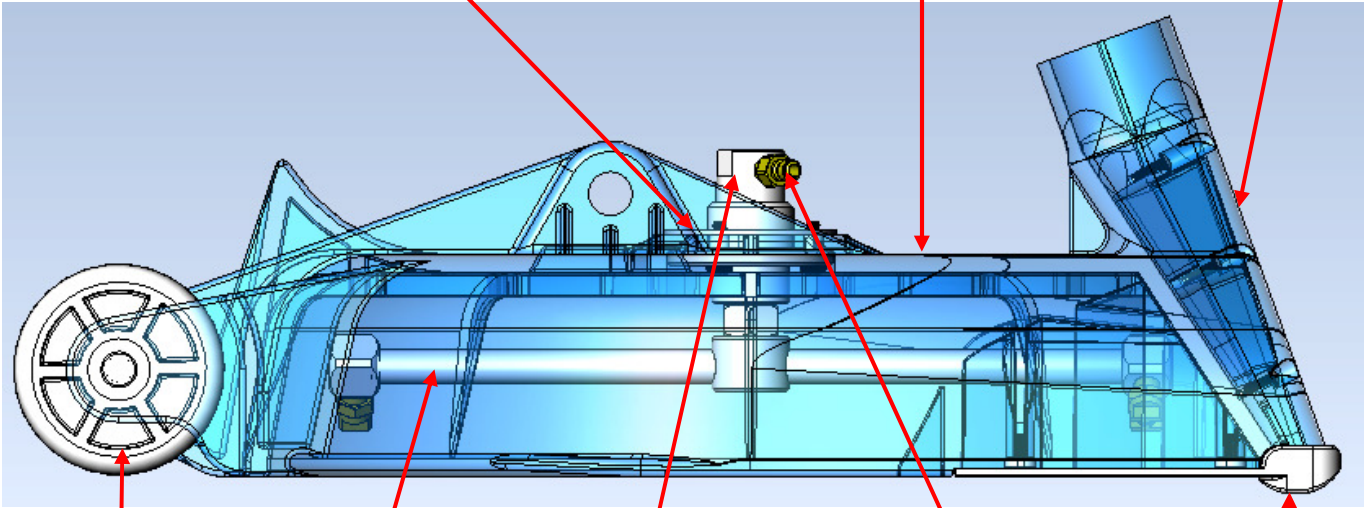

NM6006 WHEEL

NX105 SWIVEL

PKLF01 1/8" MALE QUICK CONNECT

NM6004 GLIDE PLATE

JET BAR:
COMMERCIAL - NM6024
RESIDENTIAL - NM6022

NM100676 - ROTARY WASHER WITH PEM NUTS

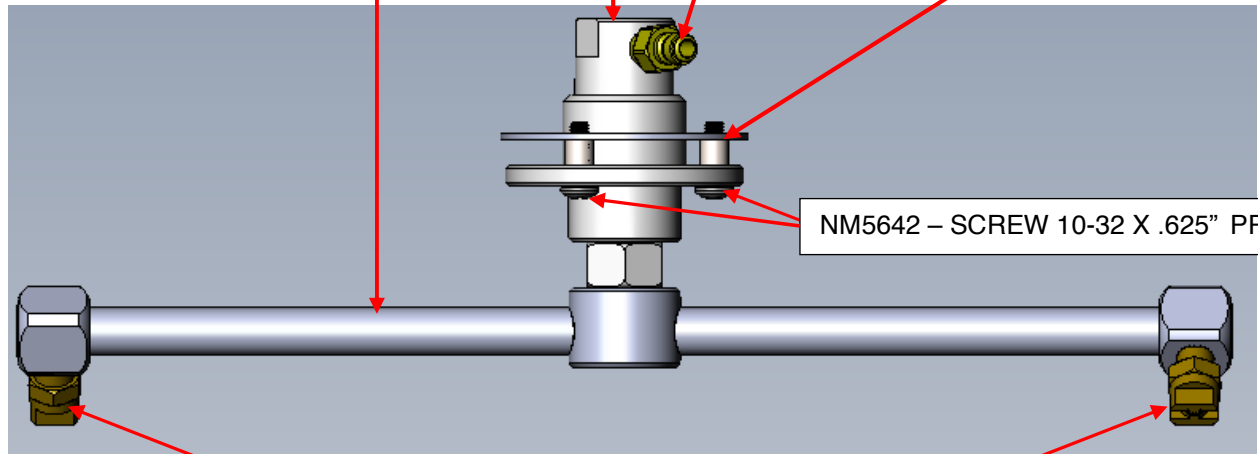

NM5642 - SCREW 10-32 X .625" PPH SS (QTY 3)

SPRAY JETS 1/8" MPT SS:
COMMERCIAL 1502 - B630
RESIDENTIAL 11002 - B344

Limited Warranty

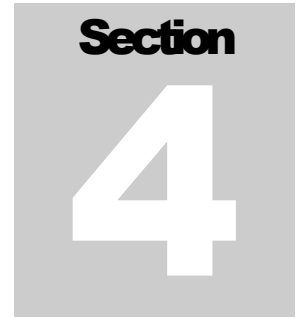

Your Hydro-Force CX-15 Rotary Carpet Extractor is designed to give you years of reliable service. If a problem should arise use the troubleshooting section in the operation manual to diagnose and correct the problem if possible.

If you are unable to determine the cause or solution to the problem contact your distributor or Hydro-Force for assistance.

Hydro-Force warrants the Hydro-Force CX-15 to be free from defects in material or workmanship for one year from the date of purchase.

During the warranty period, Hydro-Force will, at its option repair or replace components which prove to be defective. This warranty does not provide for replacement of complete units due to defective components. Transportation or related service labor are covered for 1 year for non-wear items, e.g. stainless steel handle and ST Nylon deck, but warranty work must be approved by Hydro-Force before work is started.

Replacement parts are warranted only for the remainder of the original warranty period.

This warranty shall not apply to defects resulting from improper operation, lack of maintenance, unauthorized modification, chemical incompatibility, misuse, abuse or exposure to freezing temperature conditions. It does not cover normal wear items such as filters, valve seals, hoses, jets, the Glide Plate or other items which require replacement as a result of ordinary usage.

To obtain warranty service for the Hydro-Force CX-15, contact your distributor or Hydro-Force.

No returned items will be accepted by Hydro-Force without prior authorization. All returns must have a return authorization number, issued by Hydro-Force, clearly marked on the exterior of the package.

Hydro-Force makes no other warranty either expressed or implied with respect to this product.

The remedies provided herein are the purchaser's sole and exclusive remedies. In no event shall Hydro-Force be liable for any direct, indirect, special, incidental or consequential damages.

This warranty gives you specific legal rights. You may also have other rights which vary from jurisdiction to jurisdiction.